



fondé en 2006 à Carcassonne, QBX est un concepteur et fabricant de quadricycles ultra-léger à forte singularité.

Le Prototype du Sorean est en expérimentation depuis 2021. Première présérie 2024. Homologation et série 2025.



Vitesse	45 km/h (mobilité active)
Autonomie	80 km (rayon d'action 40 km)
Poids à vide (batterie incluse)	120 kg
Charge utile	240 kg
Consommation électrique	30 Wh/km
1€ d'électricité pour parcourir 150 km	
Récupération d'énergie au freinage	



Etape 1 :

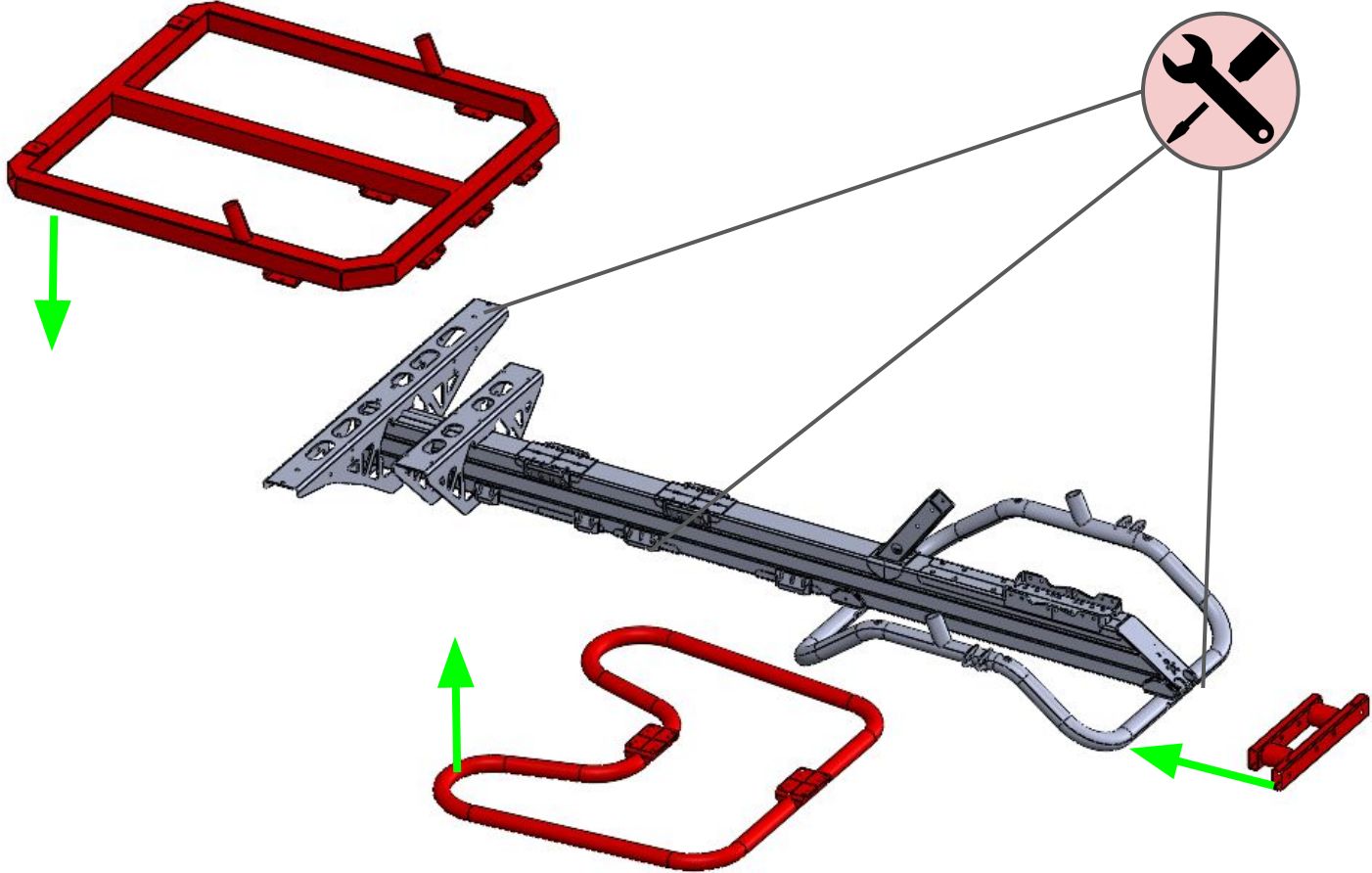



Etape 2 :

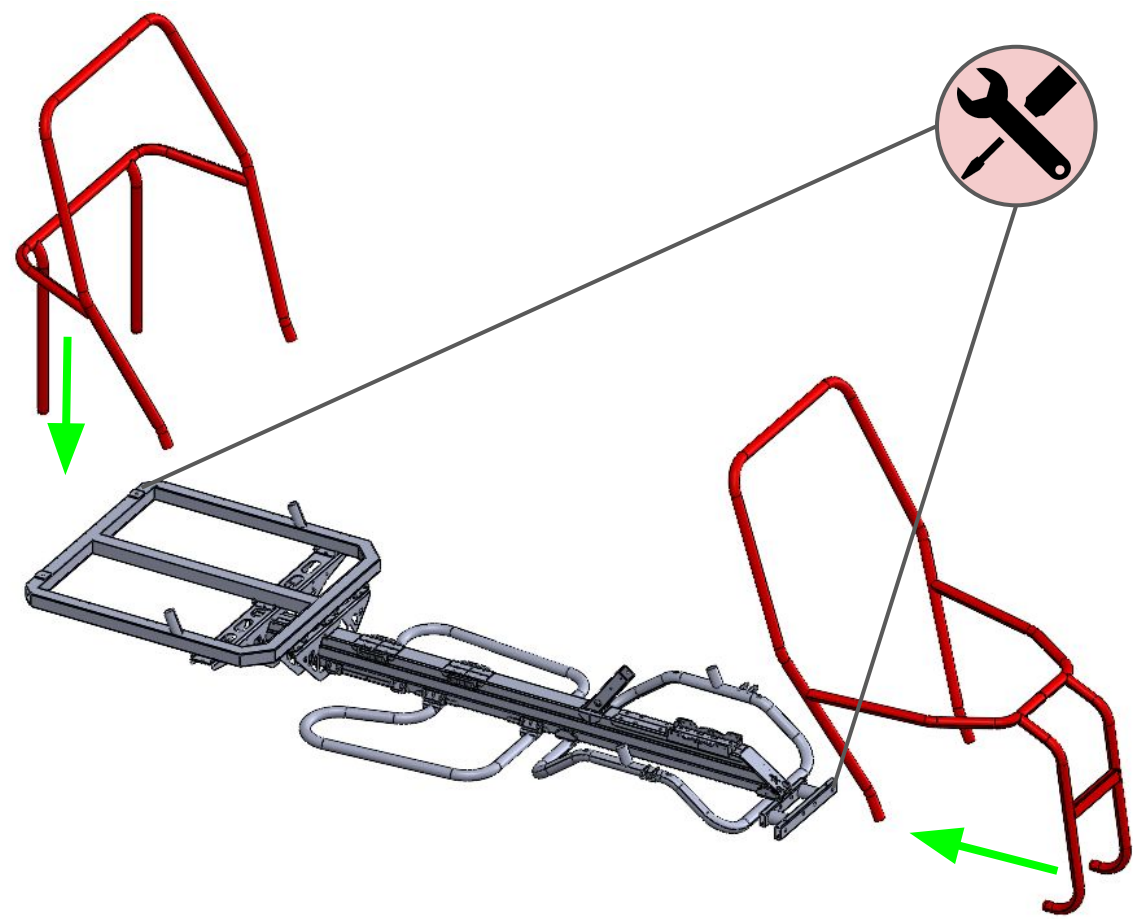



Etape 3 :

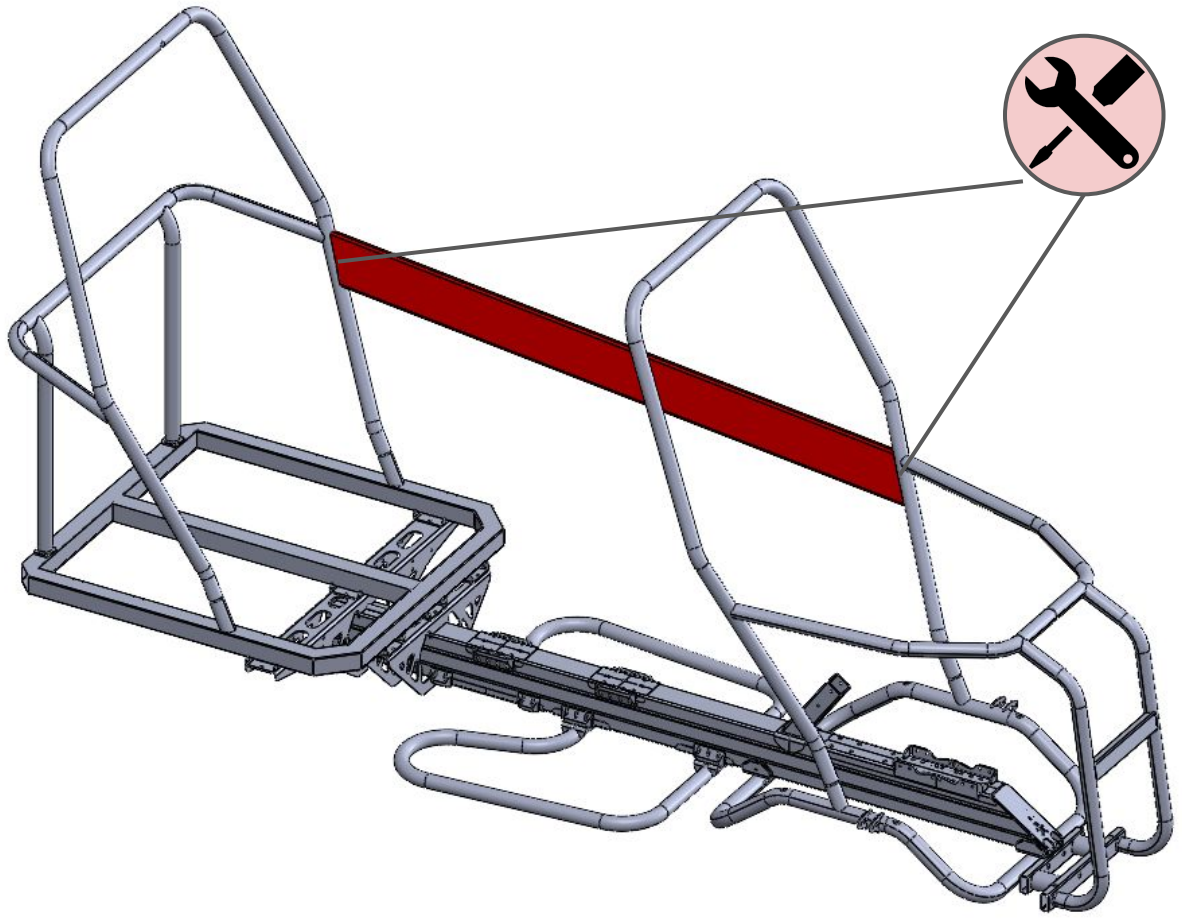



Etape 4 :

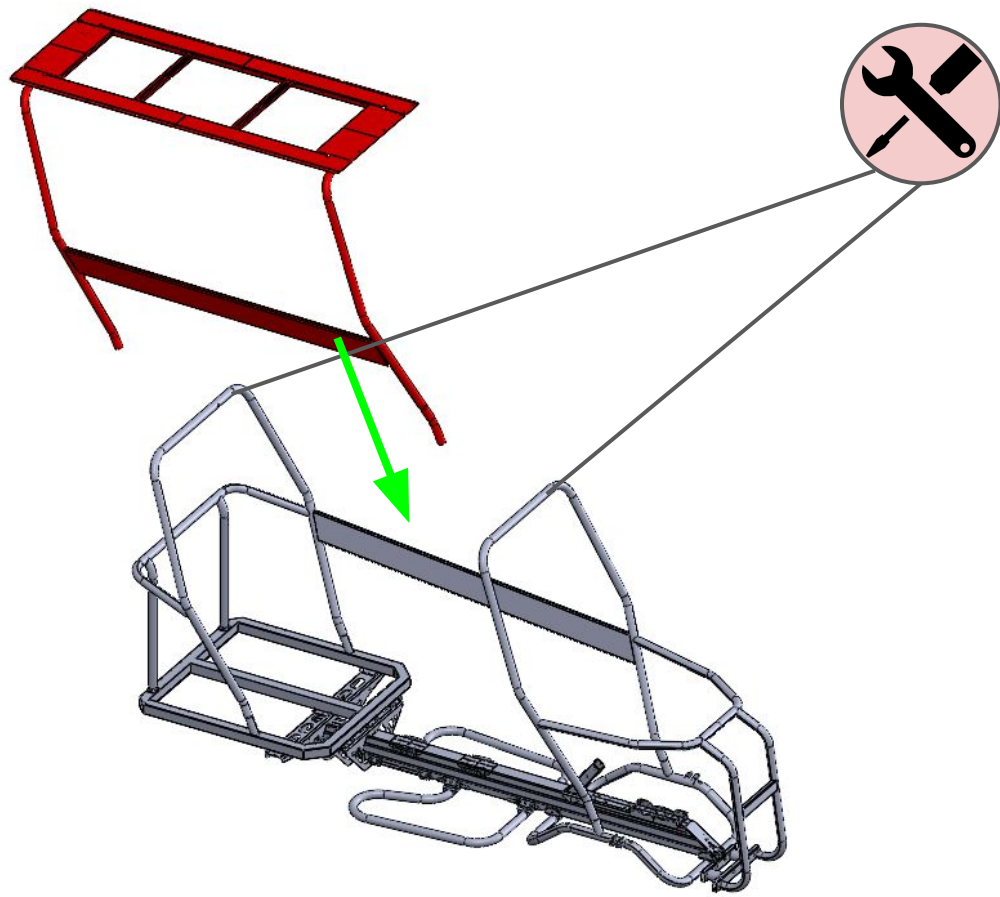



Etape 5 :

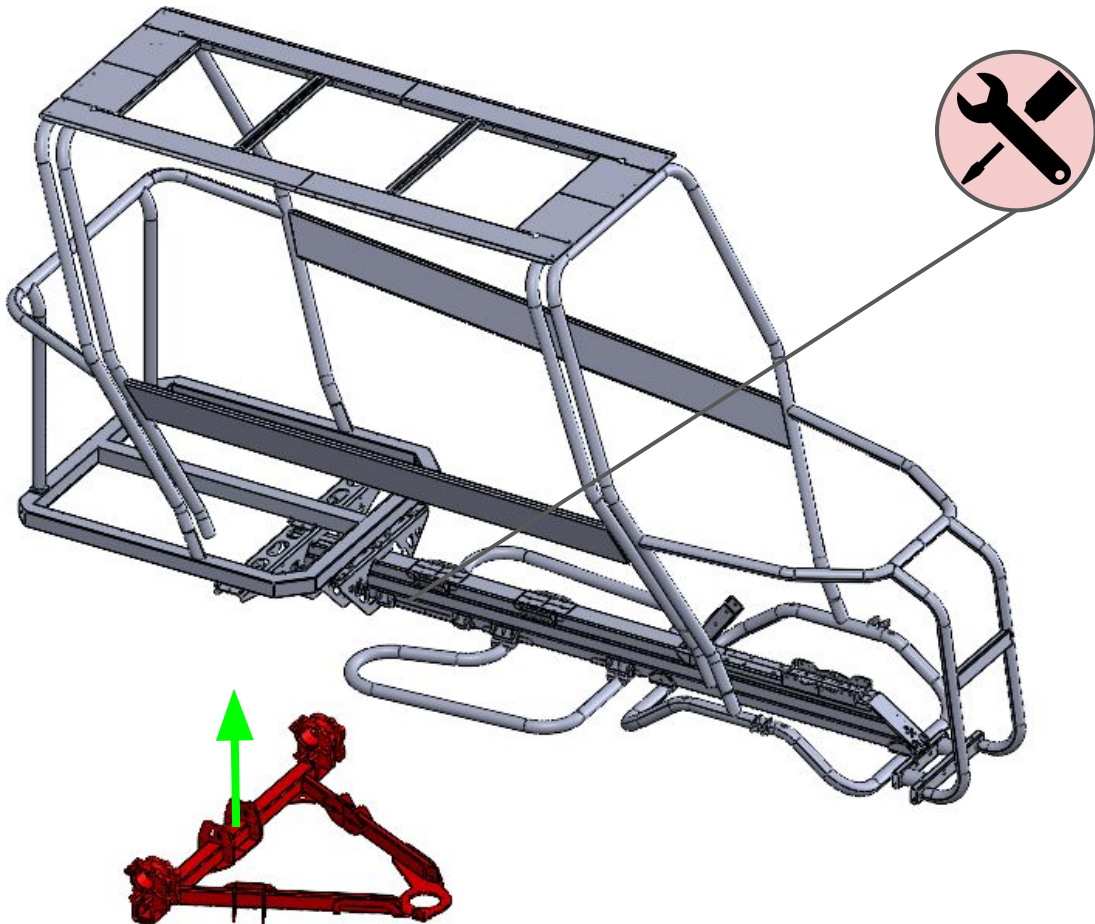



Etape 6 :

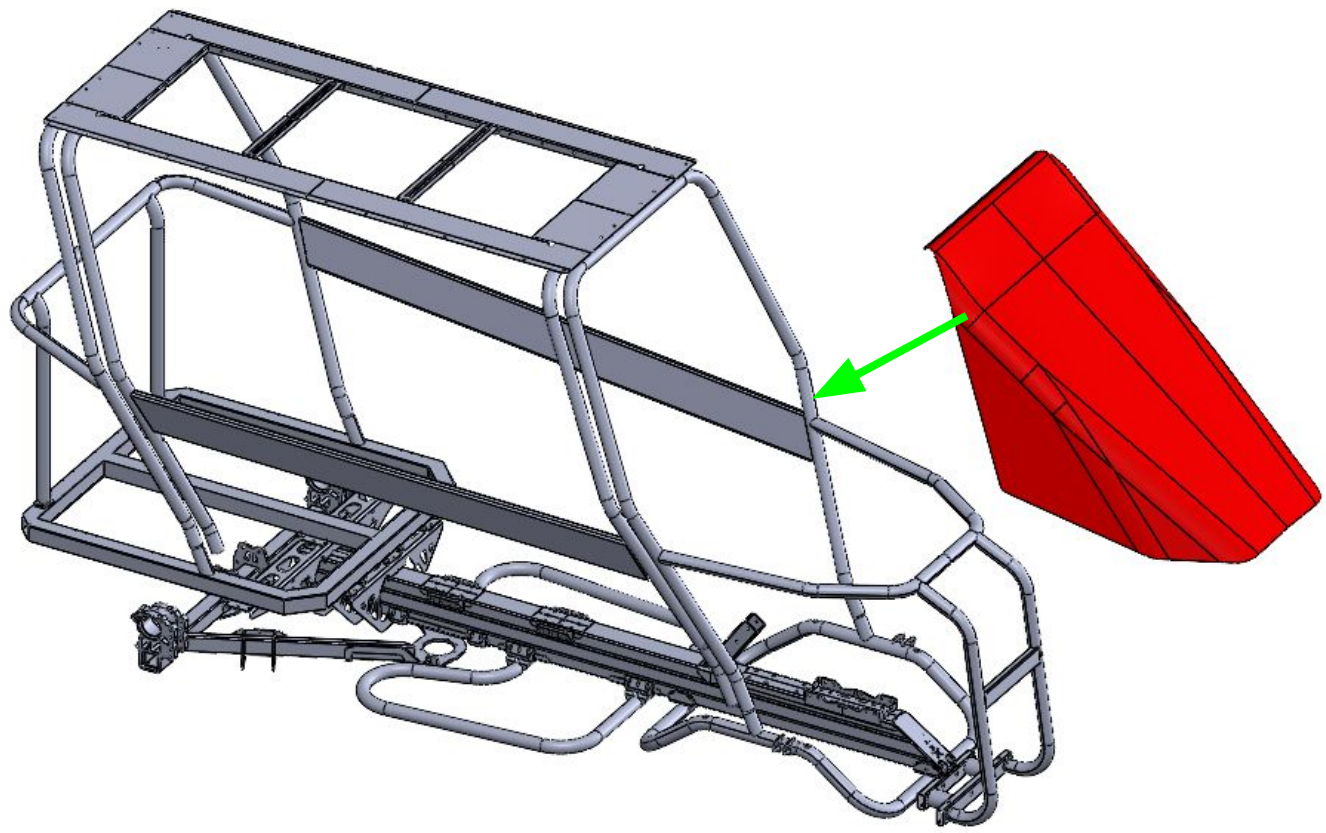



Etape 7 :

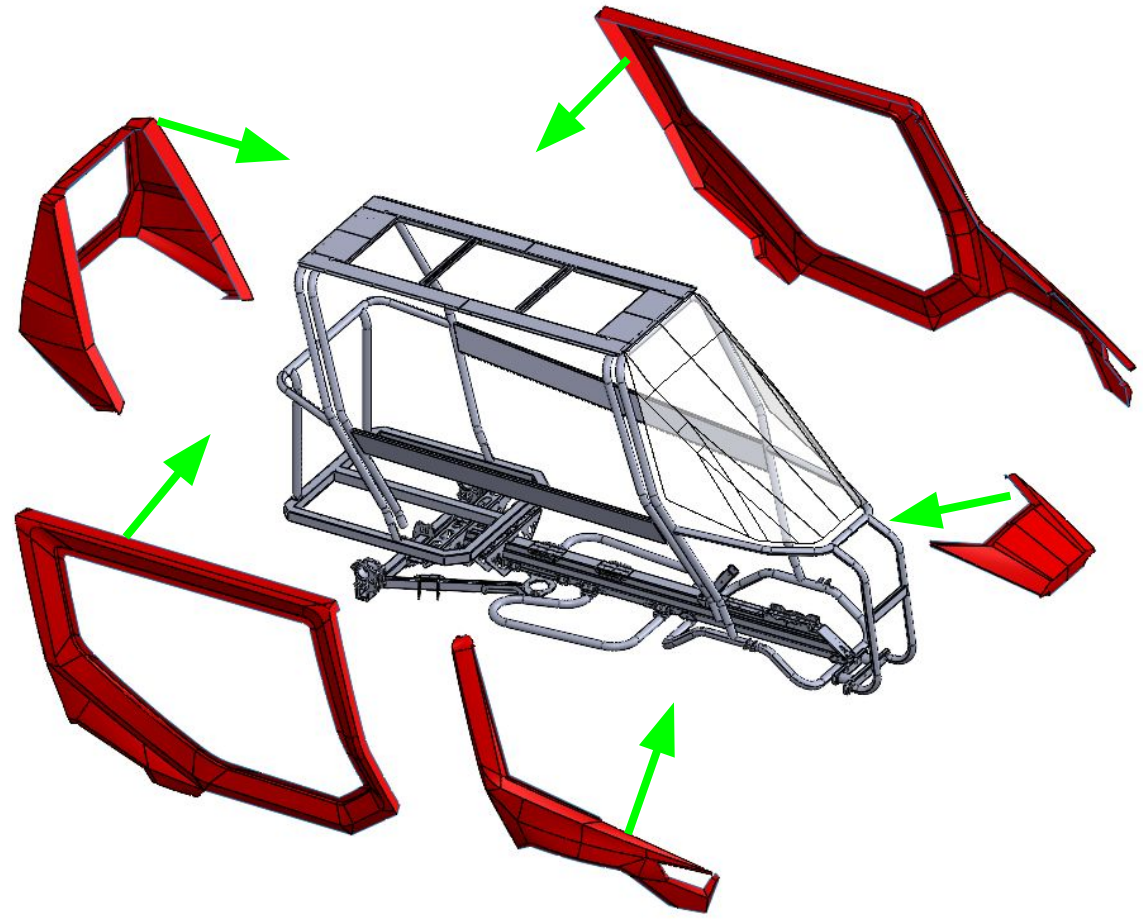

QBX
Quadbike

